

This publication supersedes and replaces any previous edition and revision. All rights reserved.  
 No part of this publication may be reproduced, stored in a retrieval system or transmitted in any form  
 or by any means, electronic, mechanical, photocopying, recording or otherwise, without permission  
 of Tecnicam s.r.l. (Bologna - Italy).  
 The technical data are not binding and may be subject to change without prior notice.

# AVC

## High speed continuous motion vertical cartoner

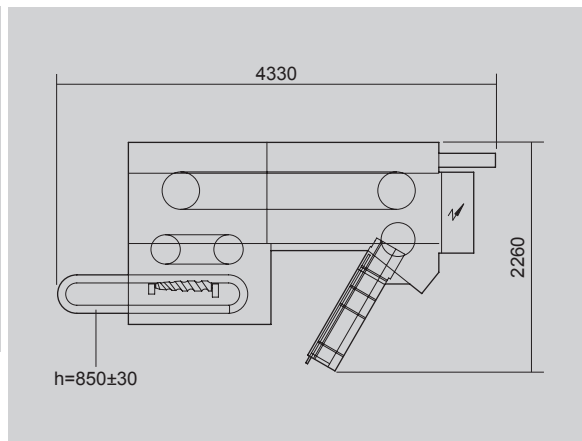
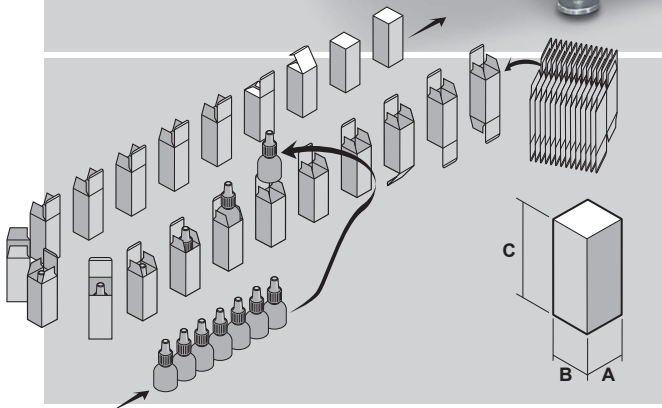

TECHNICAL DATA		AVC 1	AVC 2
Mechanical speed	<b>STROKES/1'</b>	max. 300	max. 200
Motors	<b>KW</b>	2.75	2.75
Power absorption	<b>KW</b>	3.8 (Hot-melt + 3.9)	3.8 (Hot-melt + 3.9)
Air consumption	<b>NI/1'</b>	16.9	16.9
Air pressure	<b>bar</b>	5+6	5+6
Gross weight	<b>kg</b>	~2400	~2400
Net weight	<b>kg</b>	~2000	~2000
<hr/>			
Size range	<b>AVC 1 min. max.</b>	<b>AVC 2 min. max.</b>	
<b>A</b>	30 65	35 115	
<b>B</b>	30 80	30 100	
<b>C</b>	55 250	55 250	
<b>A + B</b>	- 190	- 190	

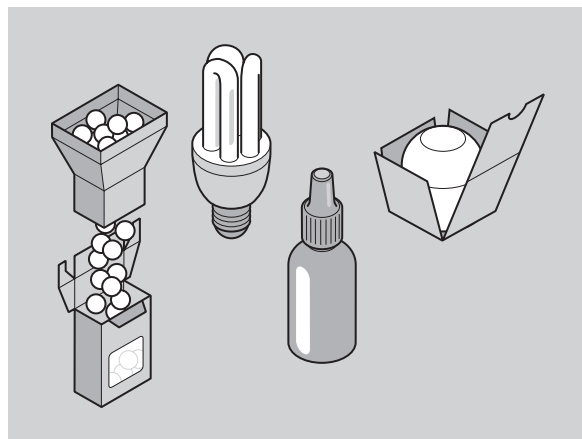

FM-AVC-02-uk (10/11/2014)