

This publication supersedes and replaces any previous edition and revision. All rights reserved.
 No part of this publication may be reproduced, stored in a retrieval system or transmitted in any form
 or by any means, electronic, mechanical, photocopying, recording or otherwise, without permission
 of Tecnicam s.r.l. (Bologna - Italy).
 The technical data are not binding and may be subject to change without prior notice.

TSA

Vertical continuous motion bottle cleaning machine with rotary table and blowing/suction system

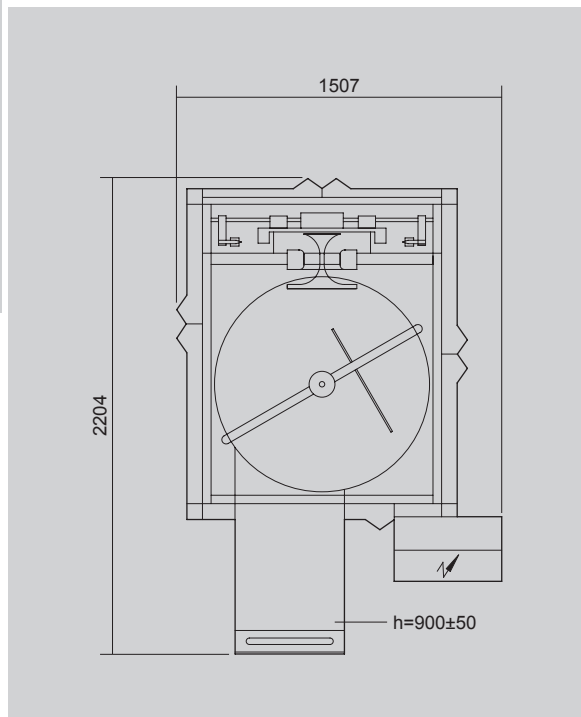
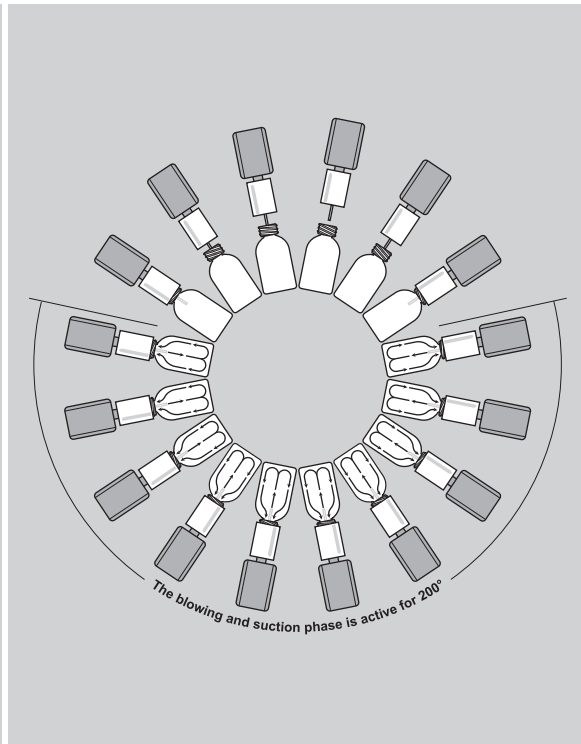

TECHNICAL DATA

Mechanical speed	STROKES/1'	140
Power absorption	KW	2.3
Air consumption	NI/1'	900
Air pressure	bar	5+6
Gross weight	kg	~1000
Net weight	kg	~800
Size range	min.	max.
Ø	20	80
c	30	180

FM-TSA-02-uk (10/11/2014)