

This publication supersedes and replaces any previous edition and revision. All rights reserved.  
 No part of this publication may be reproduced, stored in a retrieval system or transmitted in any form  
 or by any means, electronic, mechanical, photocopying, recording or otherwise, without permission  
 of Tecnicam s.r.l. (Bologna - Italy).  
 The technical data are not binding and may be subject to change without prior notice.

# TTS

## Tracking code application and reading machine

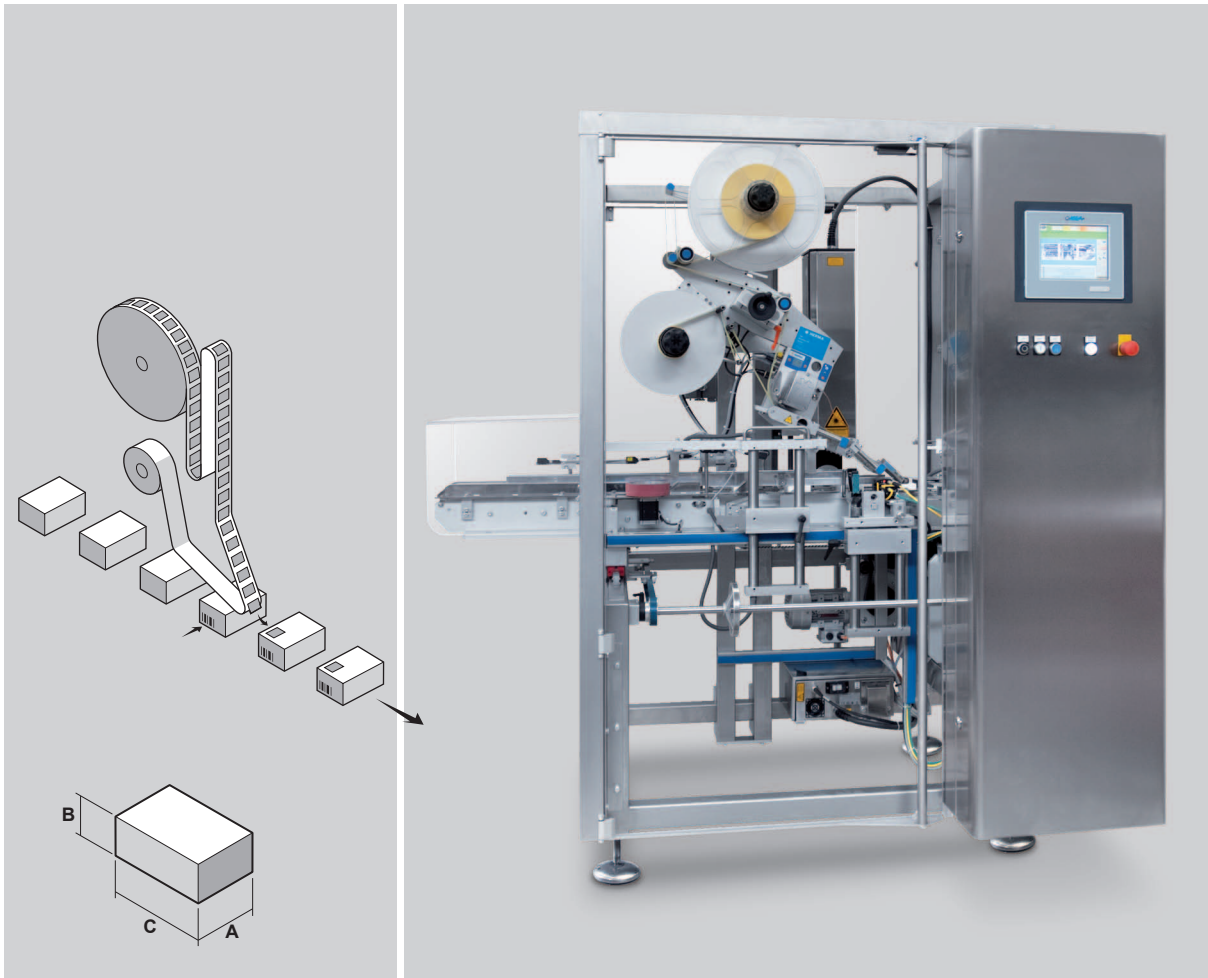

### TECHNICAL DATA

Mechanical speed	<b>STROKES/1'</b>	350
Motors	<b>KW</b>	2.5
Power absorption	<b>KW</b>	3.5
Air consumption	<b>NI/1'</b>	1
Air pressure	<b>bar</b>	5+6
Gross weight	<b>kg</b>	~158
Net weight	<b>kg</b>	~150
<hr/>		
Size range	<b>min.</b>	<b>max.</b>
<b>A</b>	25	95
<b>B</b>	16	70
<b>C</b>	70	200

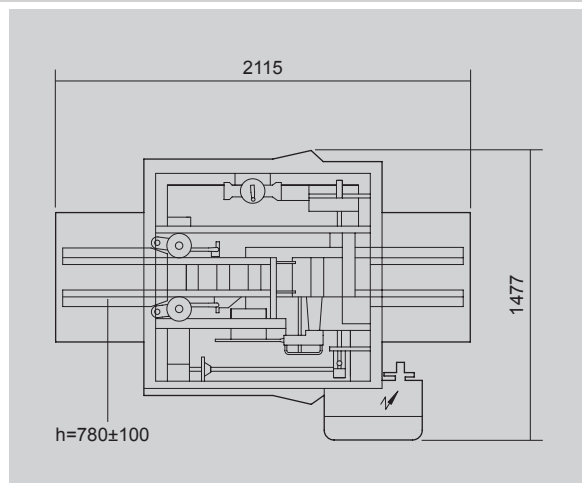

FM-TTS-03-uk (25/06/2015)