

This publication supersedes and replaces any previous edition and revision. All rights reserved.
 No part of this publication may be reproduced, stored in a retrieval system or transmitted in any form
 or by any means, electronic, mechanical, photocopying, recording or otherwise, without permission
 of Tecnicam s.r.l. (Bologna - Italy).
 The technical data are not binding and may be subject to change without prior notice.

SP-I

Robot manipulator for continuous motion machines

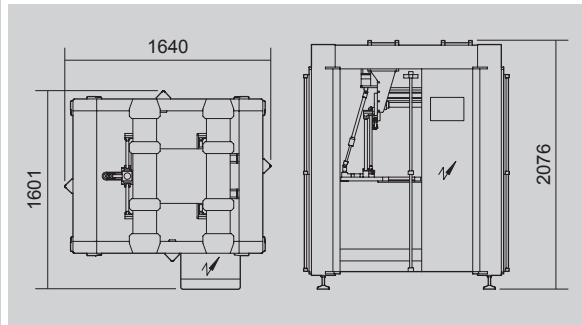
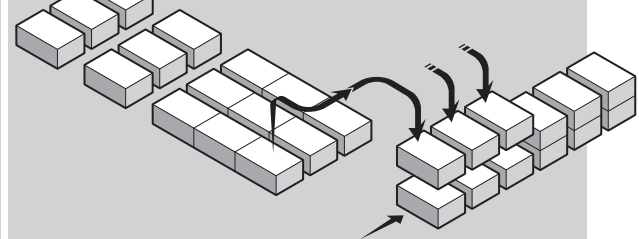
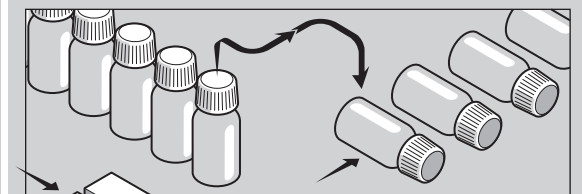
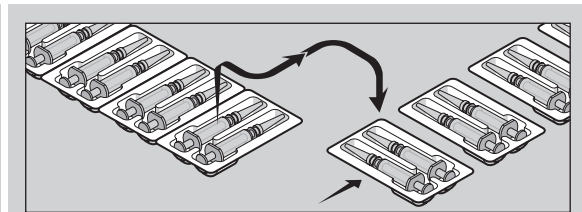

TECHNICAL DATA

Mechanical speed	STROKES/1'	60 (ISO)
Power absorption (max.)	KW	4
Air consumption	NI (cycle)	6
Air pressure	bar	4-6
Gross weight	kg	1100
Net weight	kg	950
<hr/>		
Size range	min.	max.
A	20	160
B	12	70
C	70	230
A + B	-	200

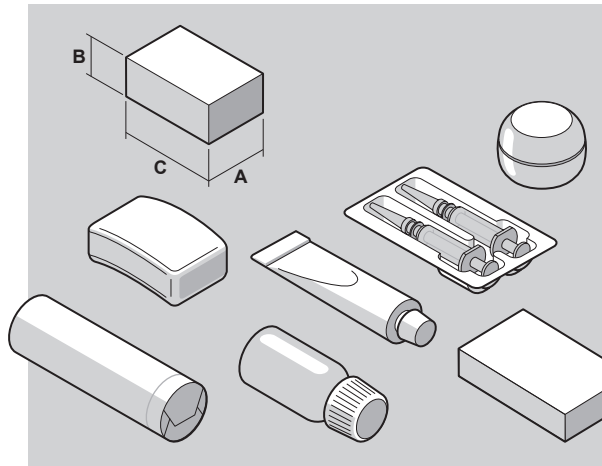

FM-SPI-02-uk (10/06/2015)