

This publication supersedes and replaces any previous edition and revision. All rights reserved.  
 No part of this publication may be reproduced, stored in a retrieval system or transmitted in any form  
 or by any means, electronic, mechanical, photocopying, recording or otherwise, without permission  
 of Tecnicam s.r.l. (Bologna - Italy).  
 The technical data are not binding and may be subject to change without prior notice.

# PMX

## Intermittent motion horizontal cartoner

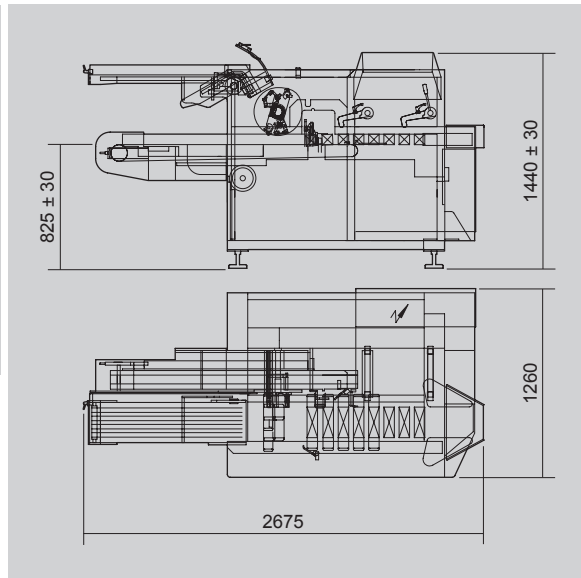
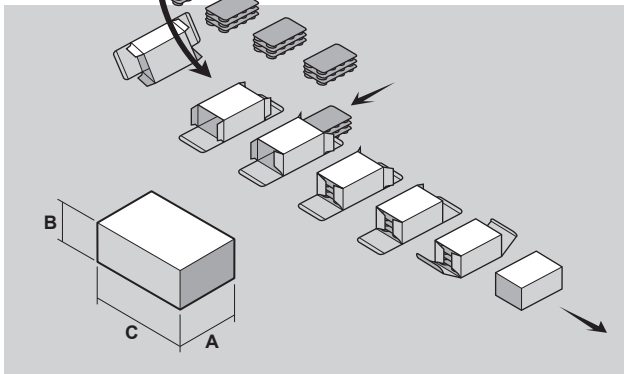
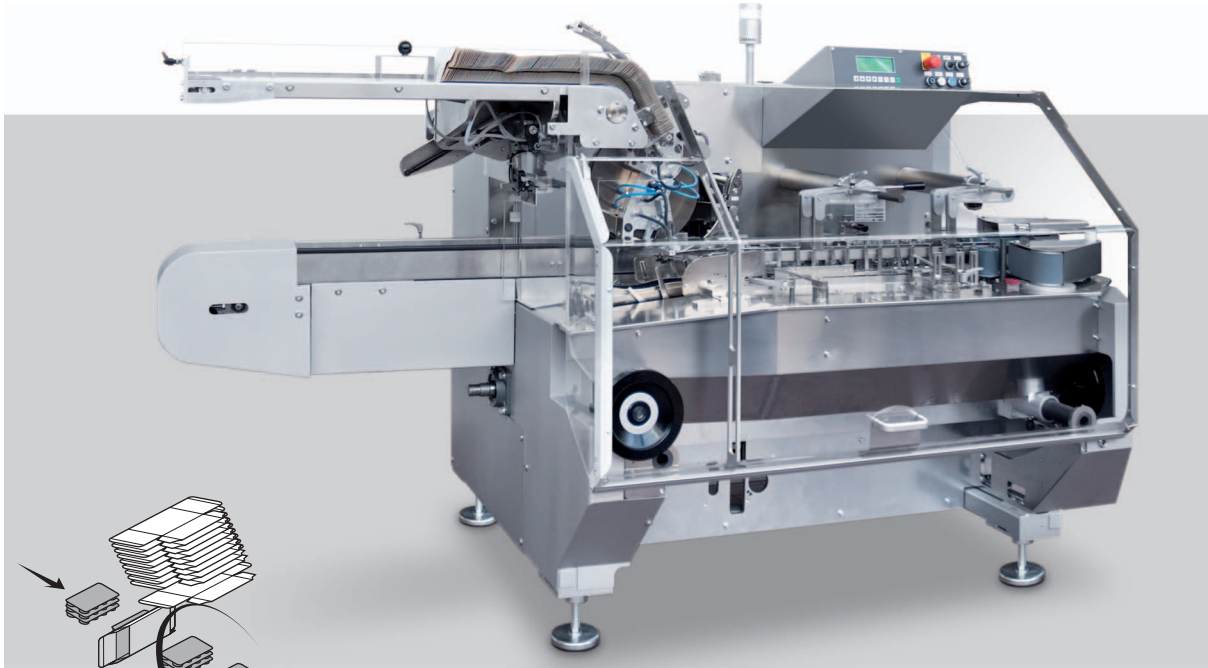

TECHNICAL DATA		PMX 1	PMX 2
Mechanical speed	<b>STROKES/1'</b>	25÷150	25÷110
Motors	<b>KW</b>	1.12	1.12
Power absorption	<b>KW</b>	1.75 (Hot-melt + 3.9)	1.75 (Hot-melt + 3.9)
Air consumption	<b>NI/1'</b>	16.9	16.9
Air pressure	<b>bar</b>	5÷6	5÷6
Gross weight	<b>kg</b>	~1400	~1400
Net weight	<b>kg</b>	~1230	~1230

Size range	PMX 1 min.	PMX 1 max.	PMX 2 min.	PMX 2 max.
<b>A</b>	15	80	20	125
<b>B</b>	12	75	15	75
<b>C</b>	65	200	65	200
<b>A + B</b>	-	155	-	170

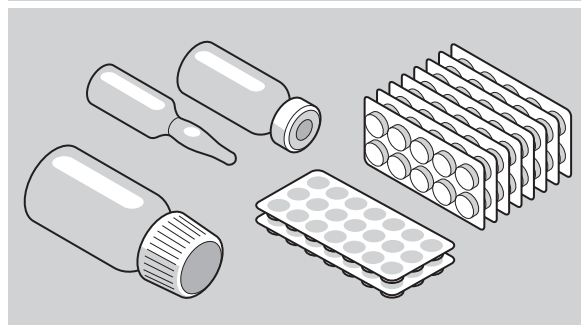

FM-PMX-02-uk (10/11/2014)