

This publication supersedes and replaces any previous edition and revision. All rights reserved.
 No part of this publication may be reproduced, stored in a retrieval system or transmitted in any form
 or by any means, electronic, mechanical, photocopying, recording or otherwise, without permission
 of Tecnicam s.r.l. (Bologna - Italy).
 The technical data are not binding and may be subject to change without prior notice.

NCX

Tray forming machine

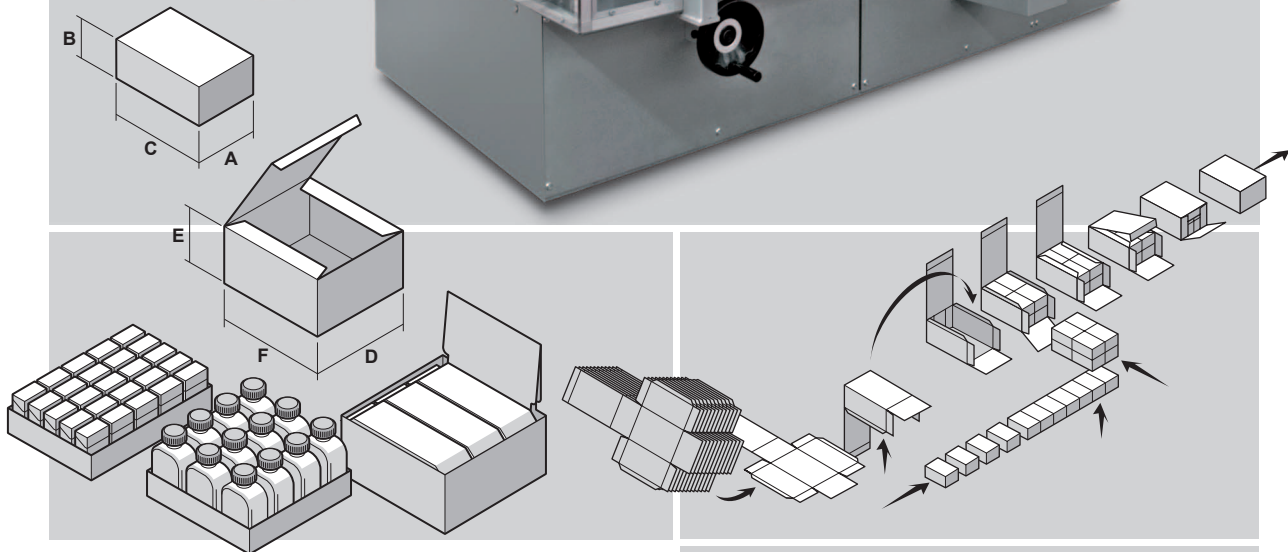
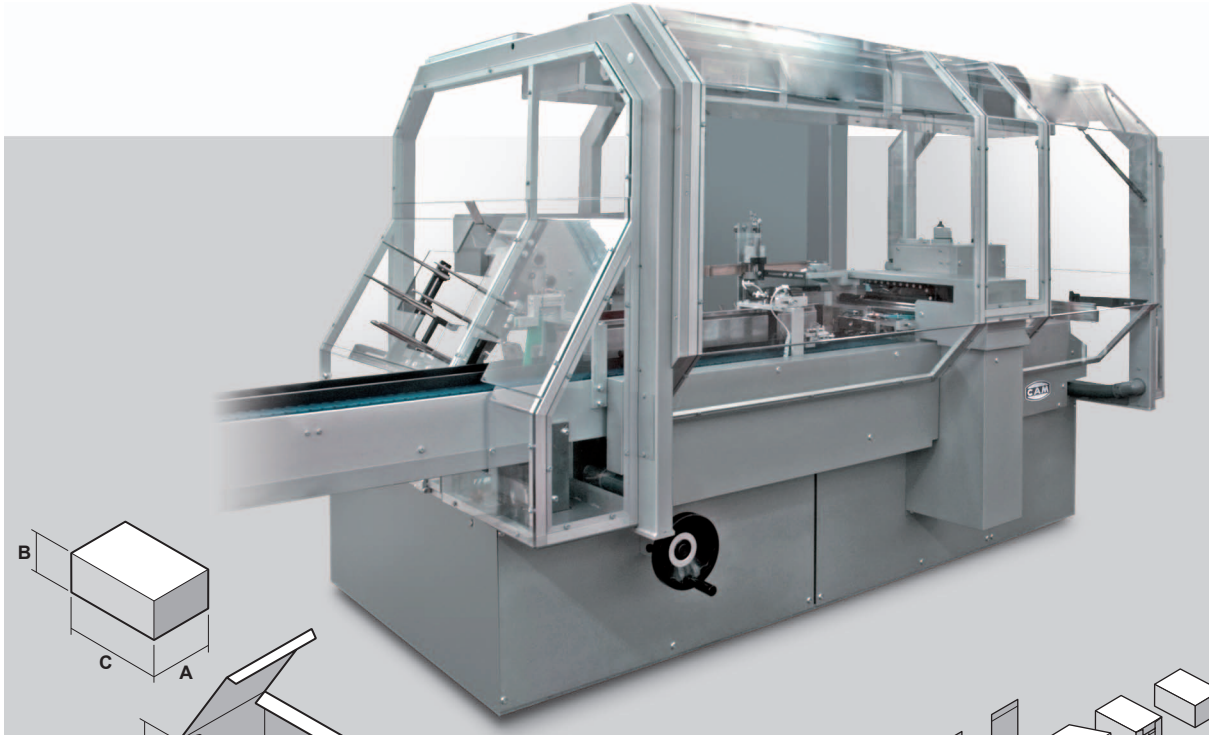

TECHNICAL DATA

Mechanical speed	STROKES/1'	max. 50
Power absorption	KW	3.5
Air consumption	NI/1'	150
Air pressure	bar	5+6
Gross weight	kg	~2100
Net weight	kg	~1600

Size range	min.	max.
A	15	200
B	10	100
C	50	150
D	50	200
E	45 (tray with lid) - 25 (tray without lid)	
F	50	200

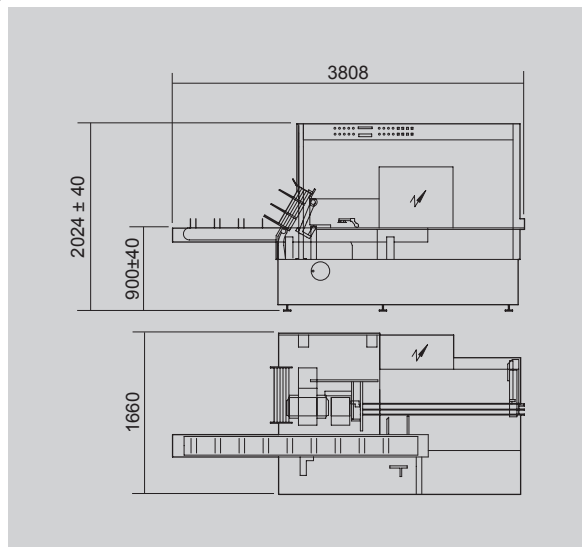

FM-NCX-02-uk (10/11/2014)