

This publication supersedes and replaces any previous edition and revision. All rights reserved.  
 No part of this publication may be reproduced, stored in a retrieval system or transmitted in any form  
 or by any means, electronic, mechanical, photocopying, recording or otherwise, without permission  
 of Tecnicam s.r.l. (Bologna - Italy).  
 The technical data are not binding and may be subject to change without prior notice.

# NV700

## Continuous motion bundler with shrink-wrapping

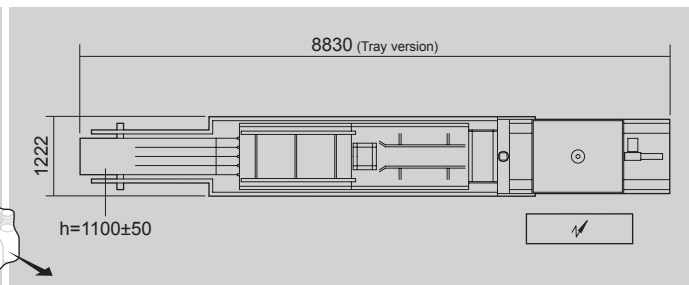
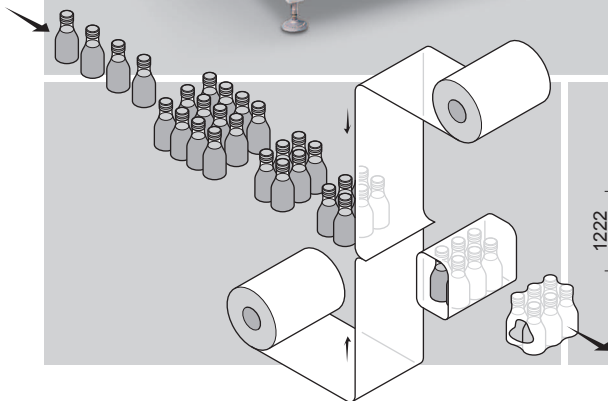

### TECHNICAL DATA

Mechanical speed	<b>STROKES/1'</b>	max. 25
Power absorption	<b>KW</b>	13
Air consumption	<b>NI/1'</b>	7
Air pressure	<b>bar</b>	6
Gross weight	<b>kg</b>	~2200
Net weight	<b>kg</b>	~2000
Size range	<b>min.</b>	<b>max.</b>
$d_i$	100	380
$e_i$	200	480
$f_i$	50	360
$H$	30	80
$d_i+e_i$	-	680
$d_i+H$	280	560
$f_i+H$	130	440

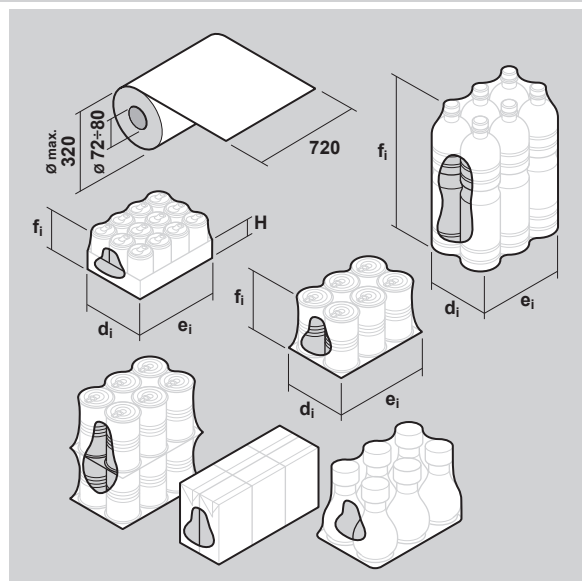

FM-NV700-02-uk (10/11/2014)